

GRAIN > GRAIN BIN SWEEPS >
UNDERBIN SYSTEMS



Complete 6", 8", and 10" underbin systems and removable sweep augers for concrete or dryer floor bins up to 49' 6" in diameter. Capacities range from 1,000 bushels per hour to 3,800 bushels per hour. Available with vertical, horizontal, or inclined powerheads and a variety of sweep accessories.

Sudenga[®]

INDUSTRIES, INC.

*Learn more
or get a quote*

Underbin Augers

Underbin systems are available in diameters of 6", 8", and 10". Shipped complete with center and intermediate sumps, control rods, and bin wall plates. Concrete and dryer floor applications both available.

Dryer floor system shown



Sweep Augers

Available for 6", 8", and 10" underbin systems for bins up to 49' 6" in diameter. Removable sweeps can be used in multiple bins with different extension configurations. Make easy work of cleaning your bins with a Sudenga bin sweep.

*Learn more
or get a quote*



WWW.SUDENGA.COM

1-888-SUDENGA | 1-712-475-3301 | Fax: 1-712-475-3320
PO Box 8, 2002 Kingbird Ave., George, IA 51237 USA
sales@sudenga.com | www.sudenga.com

GRAIN > GRAIN BIN SWEEPS >
UNDERBIN SYSTEMS

UNDERBIN AUGERS, SUMPS AND CONTROLS

Complete underbin round tube (6", 8" and 10") auger systems for bins to 49' 6" in diameter for dryer or concrete bin floor applications. Capacities range from 1,000 BPH to 3,800 BPH depending on which power head is ordered. Galvanized tube standard. Sleeved or flanged tube options.

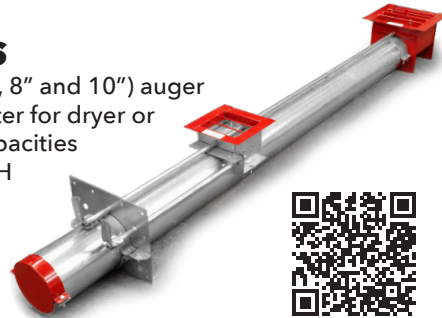

SUMPS

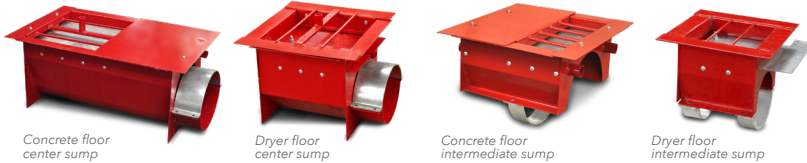

Concrete floor center sump

Dryer floor center sump

Concrete floor intermediate sump

Dryer floor intermediate sump

BIN SWEEP AUGERS

4-1/4" for 6" underbin augers, 5-1/4" for 8" and 7-1/4" for 10" underbin augers. Modular design fits a variety of bin sizes. 7-1/2' or 9' basic sections with motor mount and wheel or walkers. Extension sections in 1-1/2', 3', 4-1/2' 6' and 9' lengths. Mix basic section with extensions as necessary to fit multiple bin diameters.

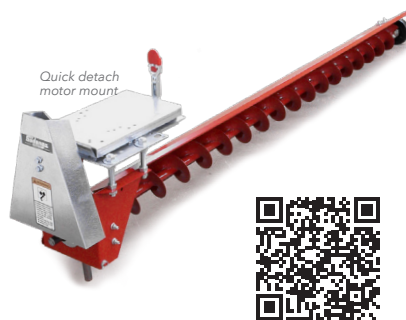

Quick detach motor mount



POWERHEADS

■ **Vertical:** 16' augers for 6", 8", and 10" underbin augers. Available with single or double drive.

■ **Horizontal:** 24" augers for all underbin augers.

■ **27° Incline:** 5' augers available for 6" and 8" underbin augers. 7' lengths available for all underbin augers.



Bin sweep walker

Sweep stop

Reduction drive end wheel

BIN SWEEP ACCESSORIES

- **Quick detach motor mount** makes motors easier to remove and sweeps lighter for moving in and out of bins.
- **Reduction drive end wheel** replaces standard rubber end wheel or steel walker. Reduces wheel spin and increases wear life.
- **Bin sweep walker** has the durability of steel wheel with better forward sweep advancement.
- **Sweep stop** bolts to the bin wall, limiting the sweep to one revolution.

UNLOADING CAPACITIES (BUSHEL/HOUR, APPROX.)*

AUGER TYPE	Transitions (Underbin to Unloading Auger)		
	6" - 8"	8" - 10"	10" - 12"
Vertical - Single Drive	1,000 - 1,200	2,200 - 2,600	3,600 - 3,800
Vertical - Double Drive	-	2,200 - 2,600	3,600 - 3,800
Right Angle Incline	1,000 - 1,200	2,200 - 2,400	3,600 - 3,800
27° Incline	1,000	2,000	3,200
	6" - 6"	8" - 8"	10" - 10"
Horizontal	1,000 - 1,200	2,200 - 2,600	3,600 - 3,800

* Capacity is reduced when the sweep is operating.

SPECIFICATIONS

Auger Dia.	Tube Gauge	Flight Gauge	Flight Pipe OD-ID
6"	14	10	1 1/4" - 1"
8"	14	3/16"	1 1/2" - 1 1/4"
10"	12	3/16"	2 1/2" - 1 1/2"
12"	12	1/4"	2-7/8" - 2"

* Collared down to 1 1/2" ID

1-888-SUDENGA | 1-712-475-3301 | Fax: 1-712-475-3320
 PO Box 8, 2002 Kingbird Ave., George, IA 51237 USA
 sales@sudenga.com | www.sudenga.com